

OTOMOTIV

Lider Markalar

Mükemmel Sonuçlar



Beresit
MAKINA

beresit makina ve sanayi ürünleri temsilcilik ve ticaret a.ş.

İÇİNDEKİLER



KAPORTA ÇEKTİRME MAKİNALARI	3-4
PUNTA KAYNAK MAKİNALARI	5-7
AKSESUARLAR	8-9
SARF MALZEMELERİ	10
GAZLATI KAYNAK MAKİNALARI	11
ELEKROD KAYNAK MAKİNALARI	12-13
TİG KAYNAK MAKİNALARI	14
PLASMA KESME - ENDÜKSİYON	15
EKİPMANLAR	16-17
CETA FORM EL ALETLERİ	18
SİLİCONİ SPREYLER - YILDIZ GAZ	19
KARBOSAN	20
MAGMAWELD KAYNAK SARF MALZEMELERİ	21
QUARK TORCLAR - SARF MALZEMELERİ	22 - 23

HAKKIMIZDA

Şirketimiz 5 Mayıs 1936 tarihinde A.R. BERESİT tarafından ithalat ve yurtdışı mümessillik işlerini yürütmek amacıyla kurulmuştur. Şirketimiz kaynak sektörüne 1960 yılında Oerlikon Kaynak Elektrodları A.Ş. bölge temsilciliği şeklinde başlamıştır. Daha sonra 1972 yılında Karbosan Zımpara Taşı Sanayi A.Ş.'nin yine bölge temsilciliği ile sanayi sektörüne hizmet etmeye devam etmiştir. 1990 yılında firmamız Oerlikon A.Ş.'nin bayilik sisteminin oluşması ile birlikte bölge temsilciliği görevini bırakmış ve bayii olarak hizmet vermeye devam etmiştir. Bu yıllarda firmamız Avrupa'dan kaynak makinası, yedek parçaları ve sarf malzemelerini ithal etmeye başlamıştır. Sonuç olarak, 2010 yılında bu alanda kendi markamızı yaratma kararı alarak QUARK ismini başlangıçta kaynak ve kesme sarf yedekleri alanında kullanmak üzere tescil etmiştir. İthalatını yapmaktan vazgeçtiğimiz ve bayiliğini yaptığımız ürünler için TSE belgeli kaynak makinaları tamir ve bakım servisimiz bulunmaktadır.



GYSPOT 2400

Sac Çektirme

230 V



GYSPOT 35.02S GYSPOT 35.04S

Sac Çektirme

230 V
400 V

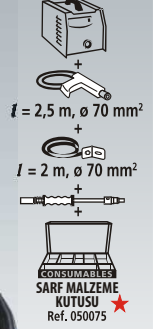

GYSPOT ALU FV

Alüminyum
Çektirme

110 V
240 V

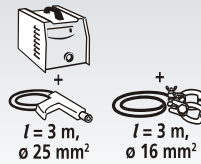

GYSPOT COMBI 230

Alüminyum
ve Sac
Çektirme

230 V

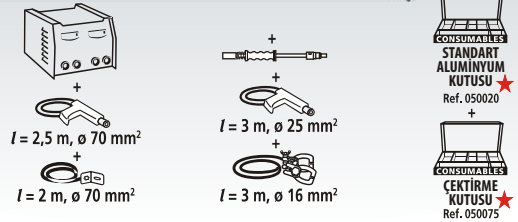

													Sinerji	Otomatik Algılama	Çıkarılabilir Tabanca
				A	I _{RMS} 3% A	I ₂ MAX A	U ₂ V	cm	kg						
GYSPOT 2400	Ref.018006	230V	50 Hz	16	1700	2400	5,4	20x18x32	16	OK	—	—	•	—	—
GYSPOT 35.02S	Ref.018075	230V	50Hz	16	2700	3500	7,2	26x23,5x36	27	OK	OK	•	•	•	•
GYSPOT 35.04S	Ref.018082	400V	50Hz 2 ph	16	2700	3500	7,2	26x23,5x36	27	OK	OK	•	•	•	•
GYSPOT ALU FV	Ref.051546	110>240V	50/60Hz	5	—	7500	50 > 200	21x24x36	14	OK	OK	•	•	•	—
GYSPOT COMBI 230	Ref.020160	230V	50Hz	16	2700 (metal)	3500 (metal) 7500 (alüminyum)	7,2 (metal) 50 > 200 (alüminyum)	45x43x29	46,5	OK	OK	•	•	•	•

PROLINER

P

Sac Gökük Çektirme Seti



SPEEDLINER COMBI 230

SC

Sac ve Metal Gökük Çektirme Seti



P



Opsiyon



Ekipmanlar ve Aksesuarlar

Sarf Malzemeleri Kutusu ★

x6 x2

cm

kg

PROLINER 230 Ref.020375

GYSPOT 35.02S

●

P

Ref 050037 + Ref 050075

PROLINER 400 Ref.020382

GYSPOT 35.04S

●

P

Ref 050037 + Ref 050075

85x76x111

66

85x76x111

66

SC



Ekipmanlar ve Aksesuarlar

ALU PULLER

Sarf Malzemeleri Kutusu ★

cm

kg

SPEEDLINER COMBI 230
Ref.020436

●

●

x2

SC

●

●

Ref 050020
+ Ref 050075
+ Ref 051515

61x69
x189

116

GYSPT 32D-X

3 Tü Kol Takımı Dahil



X Tip Kafa



C Tip Kafa



GYSPT 100R-X

3 Tü Kol Takımı Dahil



SD CARD



GYSPT 32D-X

Ref.019881

50/60Hz	RMS A	MAX A	mm	Uo		
2x 400	32 (D)	7500	10500	3+3	1,2+3	11

Cables		100% Cu	cm	kg
AIR COOLED	l	Ø mm ²		
	• 2,2m	200		
	• 2,5m	150	• 55x75 x190	100
	• 8m	3x6 H07RNF		

GYSPT 32D-C

Ref.019898

50/60Hz	RMS A	MAX A	mm	Uo		
2x 400	32 (D)	7500	10500	3+3	1,2+3	11

Cables		100% Cu	cm	kg
AIR COOLED	l	Ø mm ²		
	• 2,2m	200		
	• 2,5m	150	• 55x75 x190	100
	• 8m	3x6 H07RNF		

GYSPT 100R-X

Ref.019911

50/60Hz	RMS A	3% A	mm	Uo	
3x 400	32 (D)	10000	3+3	1,5+3	16

Cables		100% Cu	cm	kg
AIR COOLED	l	Ø mm ²		
	• 2,5m	200		
	• 2,5m	150	• 70x99 x208	103
	• 8m	4x6 H07RNF		

GYSPT 100R-C

Ref.019928

50/60Hz	RMS A	3% A	mm	Uo	
3x 400	32 (D)	10000	3+3	1,5+3	16

Cables		100% Cu	cm	kg
AIR COOLED	l	Ø mm ²		
	• 2,5m	200		
	• 2,5m	150	• 70x99 x208	103
	• 8m	4x6 H07RNF		

7 500 A • 500 daN
Hava Soğutmalı
Kablo : L = 2,5 m - Ø = 200 mm²

Hava Soğutmalı
Kablo : L = 2,5 m - Ø = 150 mm²

DAHİL:

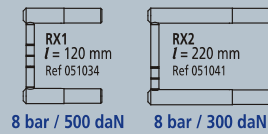

8 bar / 500 daN 8 bar / 300 daN



8 bar / 300 daN

10 000 A • 500 daN
Hava Soğutmalı
Kablo : L = 2,5 m - Ø = 200 mm²

Hava Soğutmalı
Kablo : L = 2,5 m - Ø = 150 mm²

DAHİL:

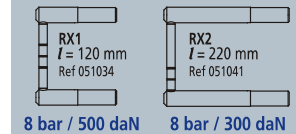

8 bar / 500 daN 8 bar / 300 daN

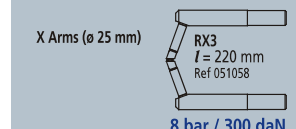

8 bar / 300 daN

Galvanizli, Yüksek Mukavemetli,
Ultra Yüksek Mukavemetli ve Boron Çeliği İçin

GYSPOT BP LX
INVERTER

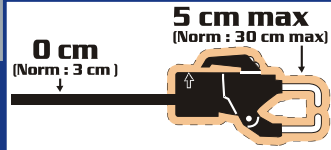

13000 A
550 daN



Galvanizli, Yüksek Mukavemetli,
Ultra Yüksek Mukavemetli ve Boron Çeliği İçin

GYSPOT BP LC
INVERTER

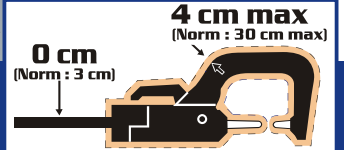

13000 A
550 daN



SD CARD



BODYPROTECT TECHNOLOGY
2004-40-CE UNIQUE ELECTRO-MAGNETIC FIELD PROTECTION by GYS

©BODYPROTECT teknolojisi ile minimum elektro manyetik alan

Compliant : Directive 2004-40-CE
Certified by : Laboratory **EMITECH**

13 000 A • 550 daN
Su Soğutmalı
Kablo : L = 2,5 m - Ø = 200 mm²

Hava Soğutmalı
Kablo : L = 2,5 m - Ø = 150 mm²

DAHİL OLANLAR :

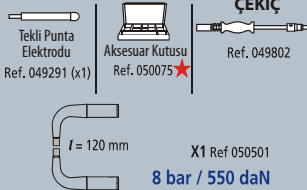

GYSPOT BP LX
Ref.019652

50/60Hz	AM	RMS	mm
A	A		
3x400	32 (D)	13000	3+3+3, 1,5+3
U _o	Kablo (l / Ømm ²)	100%	Cu
16	2,5m/200	2,5m/150	65x80 x205
	Su Soğ.	Hava Soğ.	160

GYSPOT BP LC
Ref.019669

50/60Hz	AM	RMS	mm
A	A		
3x400	32 (D)	13000	3+3+3, 1,5+3
U _o	Kablo (l / Ømm ²)	100%	Cu
16	2,5m/200	2,5m/150	65x80 x205
	Su Soğ.	Hava Soğ.	160

13 000 A • 550 daN
Su Soğutmalı
Kablo : L = 2,5 m - Ø = 200 mm²

Hava Soğutmalı
Kablo : L = 2,5 m - Ø = 150 mm²

DAHİL OLANLAR :

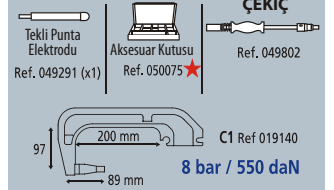

Punta Ucu Takımı



Ref. 050068



Koruyucu Branda
Ref. 050853



UPGRADE V1 - V2
KIT GYSPOT BP LX Ref. 051393
KIT GYSPOT BP LC Ref. 051751

Yönetim Kartı
Ref. 051621

Opsiyonel GYRO 360°

Bp. Lc için Ref. 051737

Evolution için Ref. 051720

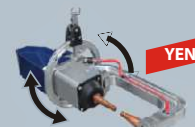

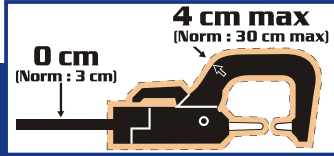

Galvanizli, Yüksek Mukavemetli,
Ultra Yüksek Mukavemetli ve Boron Çeliği İçin

GYSPOT BP LCX
INVERTER

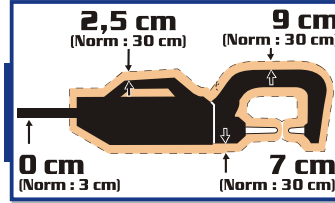
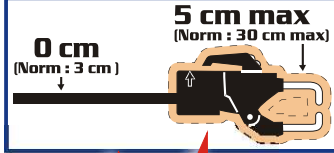

Galvanizli, Yüksek Mukavemetli,
Ultra Yüksek Mukavemetli ve Boron Çeliği İçin

GYSPOT EVOLUTION
INVERTER

13000 A
550 daN

Sisteme
2si
dahildir

SD CARD

14500 A
550 daN



13 000 A • 550 daN
Su Soğutmalı
Kablo : L = 2,5m - Ø = 200 mm²

Hava Soğutmalı
Kablo : L = 2,5 m - Ø = 150 mm²

DAHİL OLANLAR :

ÇEKİÇ
Tekli Punta Elektrodu Ref. 049291 (x1)
Aksesuar Kutusu Ref. 050075
C1 Ref 019140
X1 Ref 050501

8 bar / 550 daN
89 mm
l = 120 mm

GYSPOT BP LCX
Ref.019676

50/60Hz	A	A	mm
3x 400	32 (D)	13000	3+3+3, 1,5+3
0	Kablo (L / Ømm ²)	100% Cu	cm kg
6	2,5m / 200 Su Soğ.	2,5m / 150 Hava	65x80 x205 180

GYSPOT (4M)
Ref.019614

EVOLUTION PTI (6M)
Ref.020320

50/60Hz	A	A	mm
3x 400	25 (D)	14 500	3+3+3, 1,5+3
U _o	Kablo (L / Ømm ²)	100% Cu	cm kg
16	4 m / 6 m	2m / 200 Hava	60x80 x230 100

Opsiyonel GYRO 360°
Bp. Lc için Ref 051737
Evolution için Ref 051720

NEW

14 500 A • 550 daN
Su ve Hava Soğutmalı
Kablo : L = 4m veya 6m

Transformatörü İçinde

SIGORTA 16 > 25 A

DAHİL OLANLAR :
C1 Ref 019140
8 bar / 550 daN

Orjinal Tabanca

Tamamlayıcı Kit.
Ref.051010

UPGRADE V1 > V2

KIT GYSPOT BP LX Ref. 051393
KIT GYSPOT BP LC Ref. 051751

Yönetim Kartı
Ref. 051621

Koruyucu Branda
Ref. 050853

Punta Ucu Takımı
Ref. 050068

X TİPİ MAKİNALAR İÇİN PUNTA KOLLARI

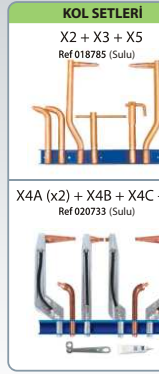
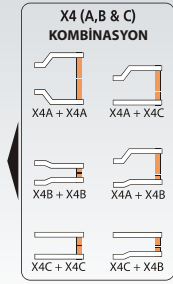
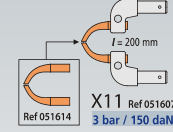
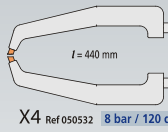
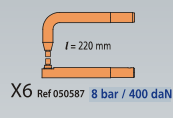
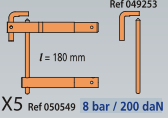
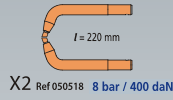
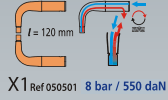
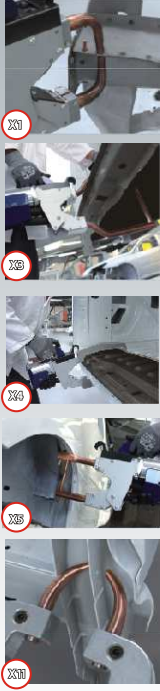

PUNTA TEST KONTROL
Ref. 050433



Test Levhaları
HLE / HTS 1,0 mm (x150) Ref 050181
THLE / VHTS 2,5 mm (x150) Ref 050167



X (Ø 25 mm) + UÇ Ø 20 mm



SARF MALZEMELERİ



Type A • Ø 13 mm Ref 049987 (x6)



Ø 13 mm Ref 049994 (x6)

Type F • Ø 13 mm Ref 049970 (x6)



PUNTA UCU KUTUSU
Ref 050068



C TİPİ MAKİNALAR İÇİN PUNTA KOLLARI

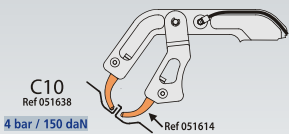
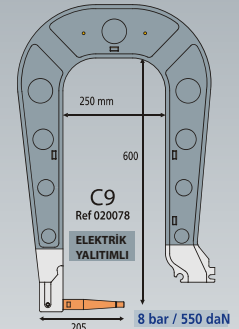
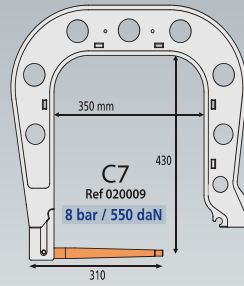
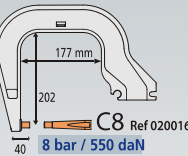
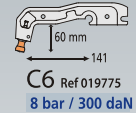
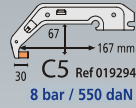
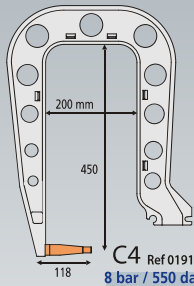
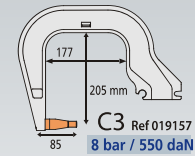
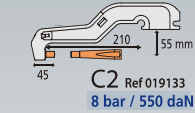
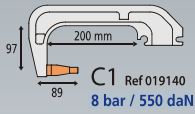

UZAKTAN KUMANDA

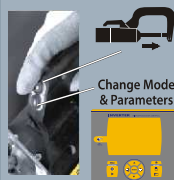

GYRO 360°



KOL SETLERİ



BOYA HASARSIZ SİLİKONLU ÇEKTİRME

Metal Yüzey İçin

230 V

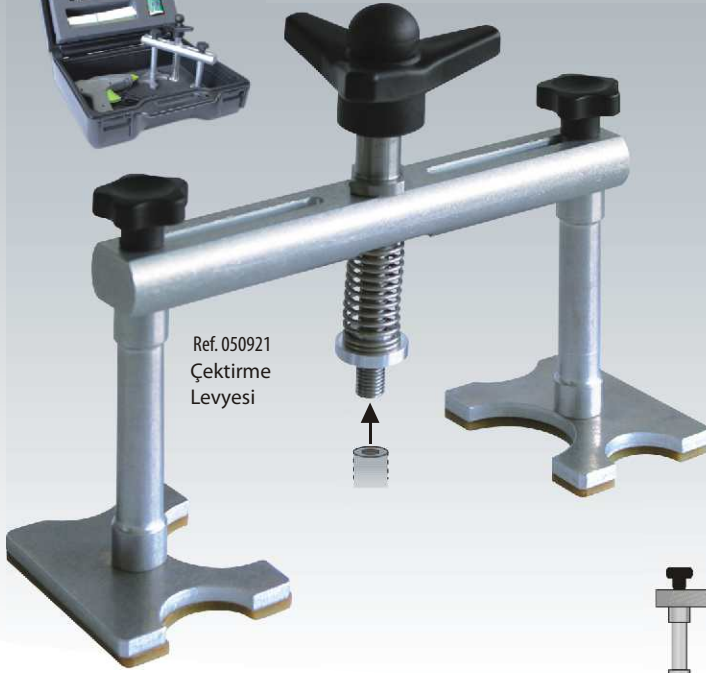
Takım
Ref. 050990Ref. 050921
Çektirme
LevyesiÇektirme
Kancası
Ref. 050969Çektirme (x6)
Pedi Ref. 050952

Dahil Olan

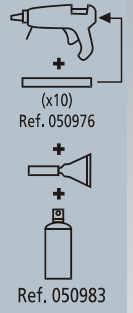
(x10)
Ref. 050976(x1)
Ref. 050983(x1)
Ref. 050983

Ref. 050983

YENİ

OPSİYON
Ref. 050051

380

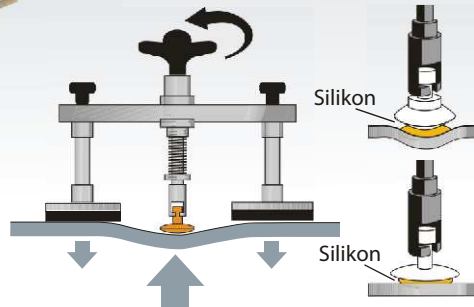
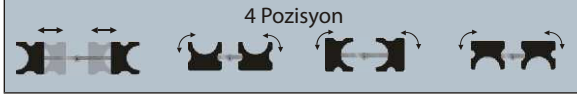

4 Pozisyon

ALUMİNYUM SARF
MALZEME KUTUSU

CONSUMABLES

STANDART
ALUMİNYUM
KUTUSU

CONSUMABLES

EKONOMİK
ALUMİNYUM
KUTUSU

Kutuda

Kutuda

Civata

Rondela

ø 4 - M4

Alu

magnesium

050273 (x200)

x200

Alu

silicium

050280 (x200)

x200

050136 (x1000)

x200

12

M4
Çektirme
Mondreli

050327 (x1)

050297 (x5)

x5

050792 (x3)

x1

050945 (x1)

050938 (x1)

049000 (x2)

Aluminyum Tabanca İçin Kolay Şase



YENİ

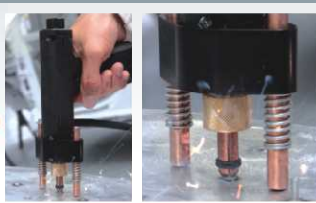

ALUMİNYUM ÇEKİÇ SETİ

4'lü Çekiç Seti
Ref. 020986

Çektirme Sarf Malzeme Kutuları



Ref. 050037



Ref. 051515



Ref. 0500751



Yıldız Çektirme Aksesuarları

	049451 (x20)	x20
	049482 (x1)	x1

Rondela Aksesuarları

	Ø16 8x16	049574 (x1)	x1
	Ø8x16	049444 (x100)	x50
		051218 (x1)	

Kare Somun Aksesuarları

	Ø16	049567 (x1)	
	M8	050303 (x100)	

Perçin ve civata aksesuarları

	Ø16 3x4,5	049604 (x1)	x1
	Ø3x3,25	049345 (x100)	x100
	Ø3x4,50	049352 (x100)	x100
	Ø2-M4	049277 (x1)	
	Ø5-M5-M6	049598 (x1)	x1
	M4x16	049383 (x100)	x50
	Ø5x12	049413 (x100)	x50
	Ø5x18	049420 (x100)	x50

Manuspot/Manuliner

	Direkt Darbe Elektrodu X5	Ref. 050839
--	------------------------------	-------------

Çektirme Kutusu Aksesuarları

	050655 (x1)	x1
	050648 (x100)	x50
	050631 (x50)	x25
	050792 (x3)	x1

Dalgali Tel Aksesuar

	049789 (x1)	x1
	049727 (x50)	x25

Manyetik Pozisyoner

	049772 (x1)	
--	-------------	--

Tekli Punta Aksesuarları

	049291 (x1)	
	Caps Type F	049970 (x6)

Yarım Ay Elektrodu

	Ø16	050310 (x1)
--	-----	-------------

Metal Çektirme İçin Kolay Şase



YENİ

Ref. 051997

Çivi Aksesuarları

	Ø2-M4	049277 (x1)	
	Ø5-M5-M6	049598 (x1)	
	Ø2	041561 (x100)	

Isı Aksesuarları

	Karbon Elektrodu	049468 (x5)	x1
	Ø16	049567 (x1)	x1

Menyetik Şase

	049666 (x1)		
	050013 (x1)	x1	
	27	049673 (x1)	x1

3'lü Elektrod Seti



Ref. 050822



SİNERJİK

T3GYS

Ref. 033108

Ref. 033023



Karoser için
HLE/THLE

YENİ



TRIMIG 205-4S

Ref. 019904



Karoser için
HLE/THLE

YENİ



Aksesuar Kutusu

Spool Gun



KORUYUCU GAZ
Argon+Co²(Çelik, Paslanmaz)
Argon (ALU/CuSi3/CuAl8)

	50/60 HZ	AM	min → max	40°C EN 60974-1	Orjinal Ekipmanı			Ø mm	Reg	cm	kg	KVA	Spool gun	
	A	A	Amax	60%										
TRIMIG 205-4S Ref 019904	400 3~	10	15 > 205	150A 25%	110A	0,6 mm 0,8 mm	3 m	0,8 mm	0,6>1,0	7	47 x 77 x 79	55	5	Opsiyonel
T3GYS Ref 033023	400 3~	10	15 > 205	150A 25%	110A	0,6/0,8 mm 0,8/1,0 mm	3 m	2 x 0,8 mm	0,6>1,0	7	60 x 90 x 90	72	5	Opsiyonel

GYSMİ 125

Demir, Çelik, Metal **230 V**



GYSMİ 131

Demir, Çelik, Metal **230 V**



GYSMİ 161

Demir, Çelik, Metal **230 V**



Gysmi 161
Ref. 016705
8,0 kg

**GYSMİ 125/131
161/165**

4'LÜ INVERTER SET 230 V



YENİ



$i_h = \dots$ MINI 20" \dots Elektrod / Saat

	I_2	$X_{GYS} 20^\circ C$	$\emptyset 1,6$	$\emptyset 2$	$\emptyset 2,5$	$\emptyset 3,2$	$\emptyset 4$	PROTEC 400 V Testi
Gysmi 125	80A	45% @ 80A	62	50	20			
Gysmi 131	130A	55% @ 115A	62	50	47	24		●
Gysmi 161	160A	60% @ 160A	62	50	47	45	22	●

60974/1	50/60 HZ	A	I_2	$X_{GYS} 20^\circ C$	Normal Kullanım	\emptyset mm	U_0	U_{ocv}	Başlangıç Voltajı v	\emptyset mm	IP	EN 60974-1 (40°C)			kg	Jeneratör (+/- 15%)
												I_A (60%)	$X\%$ (I2 max)	cm		
Gysmi 125 Ref : 015456 015586	230V	10	10 > 80A	45% @ 80 A	1,6>2,5	85	85	10/25	21	31	6	29x19x19 40x15x32	2,5	3 kW	3,7 kVA	
Gysmi 131 Ref : 016750	230V	13	10 > 130A	55% @ 115 A	1,6>3,2	80	85	10/25	21	45	5	40x15x32	2,9	4 kW	5,0 kVA	
Gysmi 161 Ref : 016705	230V	16	10 > 160A	60% @ 160 A	1,6>4	72	80	10/25	21	85	14	42x17x37	4,2	6 kW	7,5 kVA	

GYSMİ 165

Demir, Çelik, Metal 230 V

GYSMİ 195

Demir, Çelik, Metal 230 V

Kolay Parametre : Hassas Amper Ayarlama (+/- 1A) **Proses Seçme**

Ayarlanabilir Sıcak Başlangıç
Ark Gücü, Deydirek Tip

Gysmi 165
Ref. 015708

Gysmi 195 PFC
Ref. 017092

10/25 mm²

TRI 400V - 3 ph

250_A Ø1,6 x 5,0

GYSMİ 251

Demir, Çelik, Metal 230 V

TRI 400V - 3 ph

250_A Ø1,6 x 5,0

GYSMİ 253

Demir, Çelik, Metal 230 V

YENİ

HAFIF SANAYİ

Kolay Parametre : Hassas Amper Ayarlama (+/- 1A) **Proses Seçme**

Hassas Amper Ayarlama (+/- 1A)

Ayarlanabilir Sıcak Başlangıç

Deydirek Tip

AĞIR SANAYİ

35/50 mm²

GYSMİ 251 TRI SR
Ref. 010031 (Aksesuarsız)
20,5x42 x38
(18 kg)

Gysmi 251 TRI
Ref. 010017

(no accessories)

Ref. 010024

Gysmi 253 TRI
Ref. 010215

(No accessories)

Ref. 010093

(no accessories)

35/50 mm²

Pas ve Kir Önleyici Kontrol Sistemi

Gysmi 253 TRI

CE NORM. 60974/1	50/60 HZ	A	I ₂ ⚡		X _{GYS} 20°C	U ₀	U _{ocv}	Ø mm ²	IP	EN 60974-1 (40°C)		cm	Jeneratör (+/- 15%)
			MMA	TIG						I _A (60%)	X _% (I ₂ max)		
Gysmi 165 Ref : 015708	230V	16	10 > 160A	10 > 160A	65% @ 160 A	72	80	10/25	23	90	19	42x17x37 8,7 kg	6 kW 7,5 kVA
Gysmi 195 Ref : 017092	230V	13	10 > 160A	10 > 190A	85% @ 160 A	67	85	10/25	23	120	28	42x17x37 12 kg	6 kW 7,5 kVA

CE NORM. 60974/1	S	50/60 HZ	A	MMA			TIG			U ₀	U _{ocv}	Ø mm ²	IP	kg	cm	Jeneratör (+/- 15%)
				I ₂ ⚡	I _A (60%)	X _% (I ₂ max)	I ₂ ⚡	I _A (60%)	X _% (I ₂ max)							
Gysmi 251 TRI Ref : 010017 (Aksesuarsız) Ref : 010024 (Aksesuarlı)	400 V 3ph	16	10 > 250A	105	11	10 > 250A	120	16	65	80	35/50	23	8,6	15,5x40x31 12,6 kg 16,6 kg	10 kW 12,5 kVA	
Gysmi 253 TRI Ref : 010215 (Aksesuarsız) Ref : 010093 (Aksesuarlı)	400 V 3ph	16	10 > 250A	180	25	10 > 250A	200	25	100	100	35/50	23	18	21x42x32 18 kg 22kg	10 kW 12,5 kVA	

TIG 167 Demir, Çelik, Metal 230 V



TIG 167 DC HF SR
Ref. 011014
17,3 kg

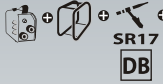

TIG 167 DC HF
Ref. 016194
14,3 kg



TIG 167 DC HF
Ref. 011021
9,3 kg

(Aksesuarsız)



L DB

TIG 200 Demir, Çelik, Metal 230 V YENİ

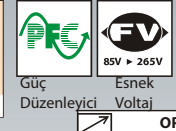
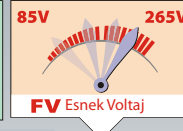
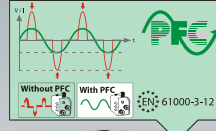

TIG 200 DC HF FV
Ref. 011533
(Aksesuarsız) 10 kg

Ref. 011540 14,3 kg



OPSİYON

Ayar Tetiği
Ref. 045682
3 kg

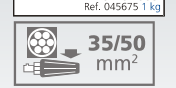

TIG 207 Demir, Çelik, Metal Alüminyum 230 V



TIG 207 AC/DC HF
Ref. 011625
17 kg

(Aksesuarsız)

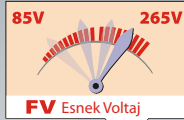

TIG 207 AC/DC HF
Ref. 011618
23,6 kg



TIG 208 Demir, Çelik, Metal Alüminyum 230 V



TIG 208 AC/DC HF
Ref. 011816
30,2 kg



TIG 208 AC/DC HF
Ref. 011823
24,6 kg

(Aksesuarsız)



CE NORM. 60974/1	50/60 HZ	A	MMA				TIG				U ₀	Ø mm ²	IP	kg	cm	kg	Jeneratör	
			X _{GYS} 20°C	Ø mm	EN 60974-1 (40°C)	I _A (60%)	X _% (t max)	I ₂	I _A (60%)	X _% (t max)							kW	kVA
TIG 167 DC HF Ref. 011021 (Aksesuarsız) Ref. 011014 (Aksesuarlı) (Shock Resistant)	230	16	10 > 160A 55% @ 160A	1,6 > 4	80	15	10 > 160A	100	21	70	35/50	23	9,3	14x37x30	6 kW	7,5 kVA		
	110	32	10 > 120A 38% @ 190A	1,6 > 3,2	90	30	5 > 180A	115	26	76	35/50	23	12,5	20x43x34 (Shock Resistant)				
TIG 200 DC HF FV Ref. 011533 (Aksesuarsız) Ref. 011540 (Aksesuarlı)	230	13	10 > 200A 46% @ 190A	1,6 > 5	125	20	5 > 200A	140	30				10	42x15x31	7 kW	8,75 kVA		
	110	32	10 > 120A 38% @ 190A	1,6 > 3,2	90	30	5 > 180A	115	26				14,3 (Aksesuarlı)					

CE NORM. 60974/1	50/60 HZ	A	MMA				TIG				Freq. Hz	Ø mm ²	U ₀	IP	kg	cm
			X _{GYS} 20°C	I _A (60%)	X _% (t max)	I ₂ min max	X _{GYS} 20°C	I _A (60%)	X _% (t max)							
TIG 207 AC/DC HF FV Ref. 011625 (Aksesuarsız) Ref. 011618 (Aksesuarlı)	110 1ph	16	100% @ 110A	90	35	10 > 160A	5 > 160A	(AC-DC) 47% @ 160A	(AC-DC) 90	20	35/50	70	23	17	20x39x35,5	
	230 1ph	13	58% @ 160A	95	21	10A	5A	(AC) 32% @ 200A	(AC) 90	20	35/50	70	23	17	20x39x35,5	
TIG 208 AC/DC HF Ref. 011823 (Aksesuarsız) Ref. 011816 (Aksesuarlı)	230 1ph	16	58% @ 160A	95	21	200A	160A	(DC) 47% @ 160A	(DC) 95	200	35/50	70	23	24,6	20x42x49	
	110 1ph	32	10 > 120A 38% @ 190A	1,6 > 3,2	90	30	5 > 180A	115	26							

PLAZMA KESME MAKİNALARI



YENİ

GÜVENLİK

+ Filter



YENİ

Kompresörlü

GÜVENLİK

+ Filter



YENİ

GÜVENLİK



85V 265V

FV Esnek Voltaj



PFC'li PFC'siz

Güç Koruyucu Sistem



60974/1

	50/60 Hz	A	I ₂ A	max mm	METAL	ALU	EN 60974-1 (40°C)		HAVA SİSTEM		IP	cm	kg	Protected & compatible POWER GENERATOR (+/- 15%)	PROTEC 400	
							I _A (60%)	X% (I ₂ max)	Basınç bar	L / mm						Kompresör İçerir
Plasma CUTTER 21 Ref. 030961	230-1~	16	5A > 20A	6	4	16A	34%	2,5>4	80	—	23	16,5x43 x26	10,4	4,1 kW	5,9 kVA	•
Plasma CUTTER 21KF Ref. 030978	230-1~	16	5A > 20A	6	4	12A	26%	3	40	•	23	21,5x45 x31	17,2	4,1 kW	5,9 kVA	•
Plasma CUTTER 31 FV Ref. 030985	230-1~	16	5A > 30A	10	8	22A	32%	2,5>6	115	—	23	18,5x41 x29	12	6 kW	7,5 kVA	•
	110-1~	32	5A > 30A			19A	25%									

İNDÜKSİYON ISITICI CİHAZI

CARDUCTION 33

Ref 051232 =



+ Ref 051249 + Ref 051256 + Ref 051263
+ Ref 051294 + Ref 051300



Filinkot için

Isıtma için

Genel İşlem için

Spatula

Ayak Tetiği

Çektirme yardımcı eleman

Boya Hasarsız Çektirme için

	50/60 Hz 1~	A	W	I ₂ MAX A	cm	kg	
CARDUCTION 33 Ref.051232	230V	16	3300	60	24 x36 x21	12	•

SOLARMAKİK BAŞ MASKESİ
(Kendinden Kararan)

MMA • MIG :
25A > 400A
TIG :
25A > 300A



ZOOM - YAKINLAŞTIRMA x 2
LCD VISION 9-13
/ EXPERT / ZEUS İÇİN
042780 (x1)



104 x 51 x 4



(KAYNAK VE TAŞLAMA ÖRTÜSÜ)

YANMAZ ÖRTÜ



ARK KORUYUCU CİHAZ 12V

ARK KORUYUCU 12V

Ref. 041318



ÖZEL AMAÇLI PENSELER

6'lı Sıkıştırma Penseleri

Ref. 050242

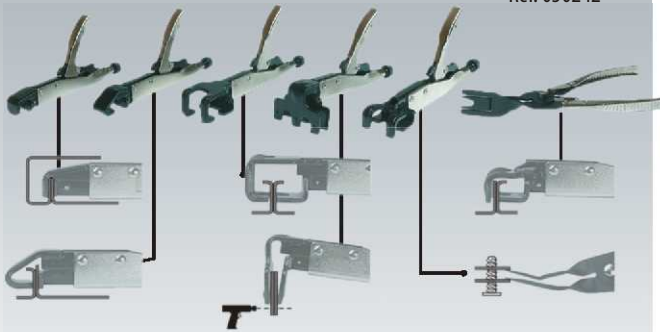

16'lı Kaporta Sıkıştırma Penseleri

Ref. 050266



6'lı Uzun Sıkıştırma Pensesi

Ref. 050112



KAPORTACI ALETLERİ SETİ

Made in
YÜKSEK
KALİTE
Germany

Ref. 051133



PNÖMATİK (HAVALI) YÜZEY TEMİZLEME SETİ



YENİ



Temizleme Süngeri

115 x 14 mm
Ref.051874

Temizleme Diski

115 x 14 mm
Ref.051843

Adaptör

pour brosse
Ref.051768

Temizleme Fırçaları

103 x 23 mm
Ref.051850103 x 23 mm
Ref.051812

Ref.051775

HIZ rpm	GÜÇ W	☞ dB	HAVA EMİŞ L/min	HAVA BASINCI bars	l cm	kg
4000	500	86	102	6,2	280	1,2

OTOMATİK MANDRELLİ
HAVALI SAĞ - SOL MATKAP

Ø 13

Ref.051799

HIZ rpm	GÜÇ W	☞ dB	HAVA EMİŞ L/min	HAVA BASINCI bar	l cm	kg
800	300	92	170	6,2	18	0,9

HAVALI TESTERE VE EĞLENME



HIZ rpm	GÜÇ W	☞ dB	HAVA EMİŞ L/min	HAVA BASINCI bar	l cm	kg
5000	—	85	255	6,2	10	0,8

FAR TEMİZLEME KİTİ
KOMPLE BAKIM SETİ

Ref.052086

Ø 76

P 500 (x 50) Ref. 052017
P 800 (x 50) Ref. 052024
P 1500 (x 50) Ref. 052031
P 3000 (x 50) Ref. 052048

PUNTA ÇÜRÜTME MATKABI
DAYMALI SİSTEMİGYSPOT DRILL
Ref.050464

DAHİL:
Karbonit Uçlar
Ref. 050396 (ø8,3)
Ref. 050402 (ø10,3)

YÜKSEK
KALİTE

HIZ rpm	GÜÇ W	☞ dB	HAVA EMİŞ L/min	HAVA BASINCI bar	l cm	kg
800	400	85	140	6,5	35	2,3



**N21-0418 FREN
BALATA KİTİ**



**N23-18 ÖN TK.
TAMİR KİTİ**



**N22-01P06
AMORTİSÖR
YAYI SÖKME
KİTİ**



**N11-02 DİZEL ARAÇLAR
İÇİN KOMPRESÖR TEST
KİTİ**



**C20-18H1 18 PARÇA 1/2
METRİK LOKMA TAKIMI**



**C28-SS40 KAPSAMLI
LOKMALI BİTS TAKIMI**



**B01-R KOMBİNE ANAHTAR
TAKIMI BEZ ÇANTA**



**B06-P07 MAFSALLI
CIRCIRLI KOMBİNE
ANAHTAR TAKIMI**



**N12-01 RADYATÖR
TEST KİTİ**



**SK10-1-54 C-PLUS T SAPLI
ALLEN ANAHTARLAR GRUBU**



**A01-06 GT PLUS TAKIM
DOLABI (6 ÇEKMECELİ)**



**C62-R09 1/2" HAVALI LOKMA
ANAHTAR TAKIMI**



**LT / 900 TOPBAŞLI UZUN ALLEN
ANAHTAR TAKIMI**



N33-04 KAPORTACI EĞESİ



**E53 STANDART
KAYNAKÇI PENSESİ**



E-55 C-TİPİ AYARLI PENSE



**C28-RT 1/2" LOKMALI
TORX UÇ TAKIMI**



**N14-071 3 KOLLU
YAĞ FİLTRE SÖKECEĞİ**



**D01-0125 1/4"
TORK ANAHTARI**



**N16-11 YENGEÇ TİP
SEGMAN PENSİ**



B21 KURBAĞACIK ANAHTAR



**N11-02A BENZİNLİ
ARAÇLAR İÇİN
KOMPRESÖR KİTİ**

PULIFREN

BALATA TEMİZLEME SPREYİ



Polimer ve solvent bazlı temizleyici sprej. Fren disklerindeki yağı ve kiri anında temizleyen güçlü bir sprejdir. Hiçbir yağ birikintisi bırakmadan hızlıca buharlaşır. Kauçuk ve plastik madde içermez. Motor dış temizliği için de kullanımı uygundur.

INOXSIL

PASLANMAZ SPREY



INOXSIL, paslanmaz çelik sprejdir. Paslanmaz çelik yüzeylerinde bir film oluşturarak tamir ve koruma işlevi görür. Tekrar boyanabilir veya son koruma olarak bırakılabilir. Tüm paslanmaz çelik yüzeylerde iyi bir örtücü olarak kullanılır.

TURBOLUX

TEMİZLEME VE POLİSAJ SPREYİ



Sentetik polimerlere dayanan bu Sprej yaparak parlattır. Arabalar, gösterge tabloları, kauçuk parçaların iç parçaları temizliği, karoser, motosikletler, mobilya parçaları için uygundur. Parfümü ile anti-duman etkisi yaratır.

SPECIAL LUBE

SİLİKON GRES SPREYİ



Silikon ve PTFE bazlı kayganlaştırıcı sprejdir. Yağlamak için uygundur. Sanayi zincirleri, araç zincirleri, sualtı ekipmanları kapılar, raylar sert kapı menteşeleri, mekanik hareketler için uygundur. Atmosferik etkenler nedeniyle, su ve güçlü bir baskıda oluşturur.

AUTOSIL

ARAÇ İÇİN YAĞLAYICI SPREY



Dielektriktir. Su barındırmaz kayganlaştırıcı sprej yüksek viskozite silikonları içermektedir. Yağlamak için formüle edilmiştir: Araba parçaları, Kapılar, Menteşeleri Kilit, Kablolar, Sualtı ekipmanları Tekne için uygundur. Parçaları korur.

PK

ÇOK AMAÇLI SPREY



Pas sökücü (cıvata, vida, vs.)
•Mekanik ve elektronik aksamlar, araba parçaları ve aletler için yağlayıcı
•Pasa karşı koruyucu film oluşturur
•Elektrik elektronik parçaların deoksidasyonu
•Su ve nemden korur
•Araba ve motor parçaları için antifriz
•Yağ sökücü

YILDIZ
GAZ ARMATÜRLERİ

KAYNAK KOLLARI



KAYNAK KESME TAKIMLARI



KAYNAK KESME VE HAMLAC TAKIMLARI



KAYNAK KESME LÜLELERİ



BASINÇ DÜŞÜRÜCÜLER



HAFİF TİP HAMLAC TAKIMLARI





BANT ZIMPARALAR

BEZ ZIMPARALAR



MOP ZIMPARALAR

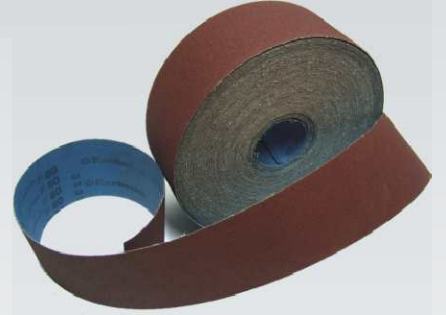

FİBER DİSKLER

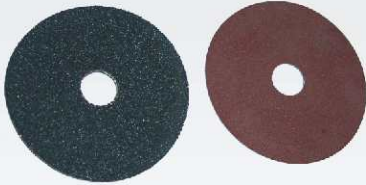

FLAP DİSKLER



FLEX ÇAPAK TAŞLARI



KESİCİ DİSKLER



Alaşımsız çeliklerin kaynağı için gaz altı kaynak teli

MG - 2

TS 5618 EN 440
AWS/ASME SFA-5.18
DIN 8559

G 42 4 M G3 Si 1
ER 70 S - 6
SG 2 CY 42 43

BELGELER & ONAYLAR

TSE, ISO 9001, BV, ABS, TL,
TUV, TUV (yenileme), RINA,
CE, DNV, GL, DB



Alüminyum ve alaşımlar gaz altı kaynak telleri

MAL 5356

TS 6204 EN ISO 18273
AWS/ASME SFA-5.10
DIN 1732

R 5356
ER 5356
SG Al Mg 5

MAL 4043

TS 6204 EN ISO 18273
AWS/ASME SFA-5.10
DIN 1732

R 4043A
ER 4043
SG Al Si 5

MAL 4047

TS 6204 EN ISO 18273
AWS/ASME SFA-5.10
DIN 1732

R 4047A
ER 4047
SG Al Si 12



Bakır ve bakır alaşımları için gaz altı kaynak telleri

MCU Si 3

AWS/ASME SFA-5.7
DIN 1733
M.No.

ER CuSi-A
SG Cu Si 3
2.1461

MCU Al 8

AWS/ASME SFA-5.7
DIN 1733
M.No.

ER Cu Al - A1
SG Cu Al 8
2.0921



Q - 15 MIG GAZALTI KAYNAK TORCU

KOMPLE TORÇLAR

Q - 15 / 3mt.	1.001.0153
Q - 15 / 4mt.	1.001.0154

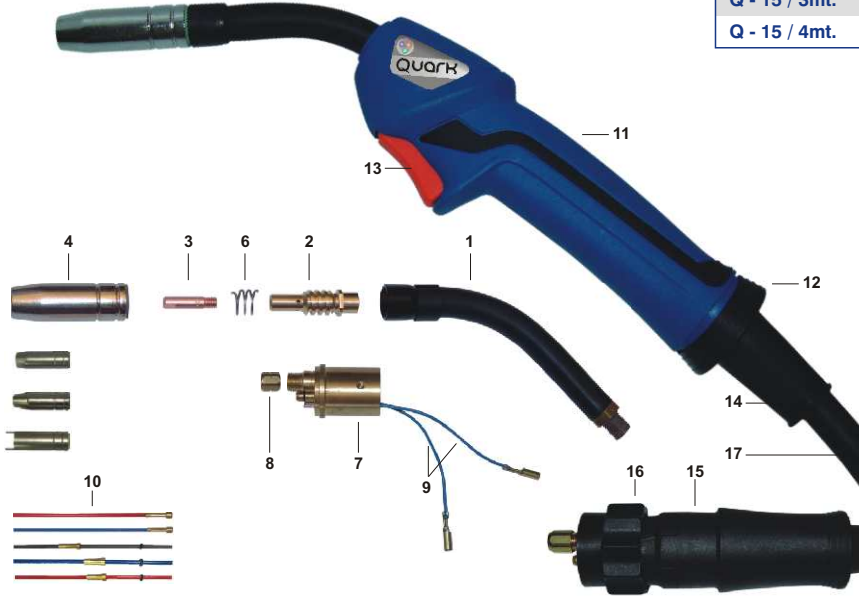

NO. PARÇA ADI

1	BOYUN
2	MEME TUTUCU
3	MEME M6x25mm - Ø 0,6mm MEME M6x25mm - Ø 0,8mm MEME M6x25mm - Ø 1,0mm MEME M6x25mm - Ø 1,2mm
4	NOZUL 15 - Ø 12mm NOZUL 15 - Ø 9,5mm NOZUL PUNTA
6	NOZUL YAYI
7	KONNEKTÖR
8	KONNEKTÖR NİPELİ
9	KONNEKTÖR PİMİ(ERKEK)
10	SİRAL 0,6 - 0,9 - 3mt. SİRAL 0,6 - 0,9 - 4mt. SİRAL 0,6 - 0,9 - 5mt. TEFLON 4mt.
11	KABZA
12	KABZA MANŞONU
13	TETİK
14	KABLO KORUYUCU
15	ARKA KABZA
16	ARKA KABZA SOMUNU
17	TORÇ KABLOSU 3mt. TORÇ KABLOSU 4mt.

TEKNİK ÖZELLİKLER

Voltaj Seviyesi	L
Soğutma	Hava
Kullanılabilir Ø mm.	0.6 - 1.0
Devrede Kalma Oranı % 60	180A. CO ₂ - 150A Karışım

PLAZMA TORCU Q-45

Pilot Arc

TEKNİK ÖZELLİKLER

Hava Geçişi	165 l/Min
Hava Basıncı	4.5 - 5.0 BAR
Devrede Kalma Oranı %60	50 Amp

NO. PARÇA ADI

1	Q-45 PLAZMA TORCU 6 MT.
1	BOYUN
2	ELEKTROD
3	DİFÜZÖR
4	MEME
5	KEP
	KEP 4 DELİK
	KEP 6 DELİK
6	SHIELD

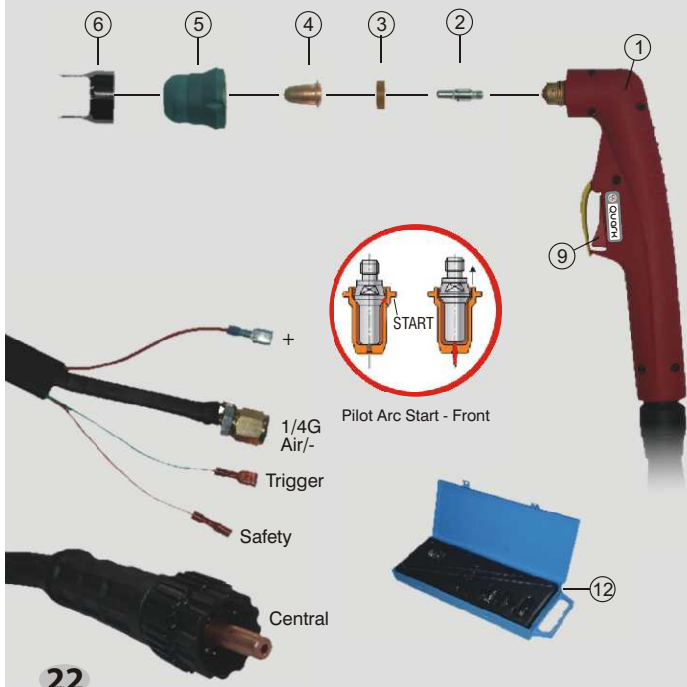

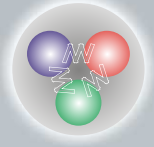

Quark
Sonsuz kaynagımız

MiG



TIG



PLASMA



Quark TIG - MiG - PLASMA SARF MALZEMALERİ





Lider Markalar

Mükemmel Sonuçlar



Beresit Makina ve Sanayi Ürünleri Temsilcilik ve Ticaret A.Ş.

Merkez: Işıklar Sitesi 6172 Sok. No:2/2-3

35070 Işıkkent - İZMİR - TÜRKİYE

Tel: +90(232) 472 12 52 **Fax:** 472 12 24

www.beresit.com

Şube: 1145/6 Sokak No:16 35110

Yenişehir - İZMİR - TÜRKİYE

Tel: +90(232) 457 52 55 - 56 **Fax:** 459 15 85

e-mail: info@beresit.com